

# OPTIMUM-8

SMALL, POWERFUL, ELEGANT SUBWOOFERS WITH AUTO-EQ

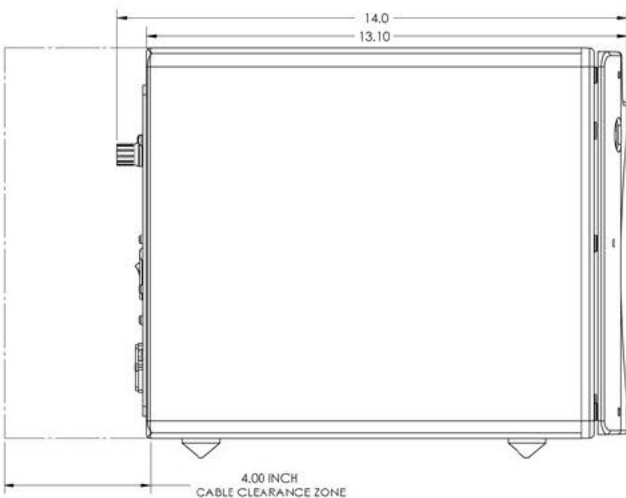
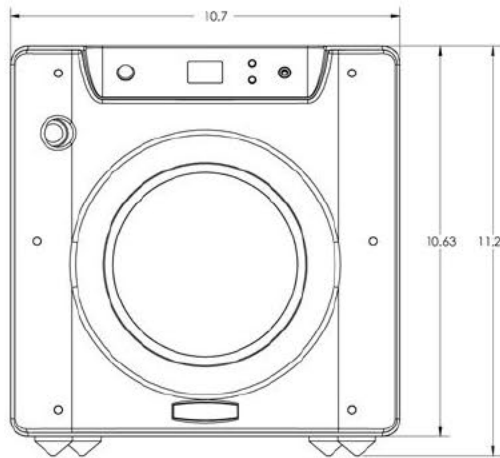

## Features

- *Tiny cabinet dimensions*
- *An intuitive front panel interactive display*
- *One-button 7-band room bass correction*
- *DSP digital control*
- *Full feature remote control*
- *4 customized listening mode presets*
- *Patented Energy Recovery System (ERS) amplifiers (2400 watts Dynamic Power)*

## SPECIFICATIONS

Model	Optimum-8
Woofer	8" forward firing (6.5" piston diameter)
"ERS" Class "D" Amplifier	2400 watts Dynamic 1200 watts RMS Power
High Pass Crossover	80 Hz (6 dB/octave)
Low Pass Crossover (Adjustable)	40-135 Hz 12 dB octave initial, 24 dB octave ultimate
Frequency Response	Overall (+/-3 dB) 16-240 Hz 26-135 Hz
Harmonic Distortion	<5% (typical)
Magnet Structure	204 oz. (12.7 lbs)
Voice Coil	2.5" Dual Layer inside/outside wound
Inputs	Line and Speaker Level
Outputs	Line-level, 80 Hz up
Phase	0°, 90°, 180°, 270°
Video Shielded	No
Dimensions (H/W/D) (inc. feet, grille and knobs)	11.2" x 10.7" x 14" (28.4 x 27.2 x 35.6 cm)
Cabinet	Sealed enclosure
Finish	Hand-rubbed black gloss lacquer or cherry veneer
Accessories	Mic, mic stand, and remote control
Shipping Weight (approx.)	33 lbs. (15 Kg)